



LB1-UW12-x Cabinet Loudspeakers



- ▶ **Good speech intelligibility and background music reproduction**
- ▶ **Available in black or white**
- ▶ **MDF construction**
- ▶ **Complies with international installation and safety regulations**

The LB1-UW12-x is a 12 W, general-purpose, cost-effective loudspeaker for indoor use. Keyholes at the rear provide quick and easy wall mounting. The angled front baffle results in a better sound in the listening area. The cabinet is available in black or white.

leading to higher customer satisfaction, longer operating life, and much less chance of failure or performance deterioration.

Safety

acc. to EN 60065

Functions

The robust, solid MDF (Medium Density Fiber board) enclosures are covered with a durable, easy-to-clean vinyl in a choice of white or black. The ABS fronts are covered with fine woven cloth in matching color.

The angled front baffle results in improved high frequency reproduction in the listening area.

Installation/Configuration Notes

Three keyholes in the rear panel provide easy and quick wall mounting. A convenient easy-to-use, 4-pole push-in terminal block is present on the rear panel for on-site wiring. This terminal block has provision for power tapping on the 100-volt, matching transformer in the cabinet. It allows selection of nominal full-power, half-power or quarter-power radiation (in 3 dB steps).

Certifications and Approvals

All Bosch loudspeakers are designed to withstand operating at their rated power for 100 hours in accordance with IEC 268-5 Power Handling Capacity (PHC) standards. Bosch has also developed the Simulated Acoustical Feedback Exposure (SAFE) test to demonstrate that they can withstand two times their rated power for short durations. This ensures extra reliability under extreme conditions,

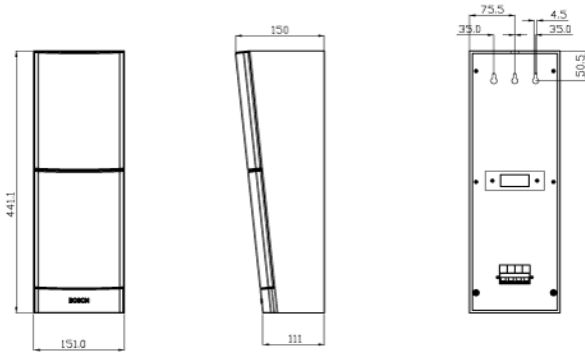

Dimensions in mm

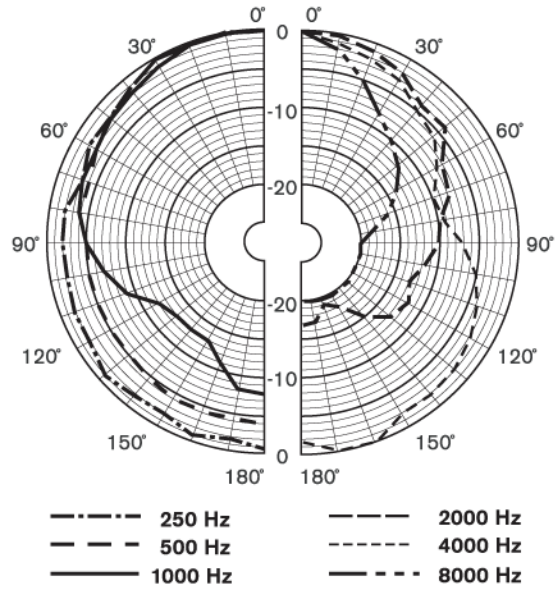

Polar diagram horizontal (measured with pink noise)

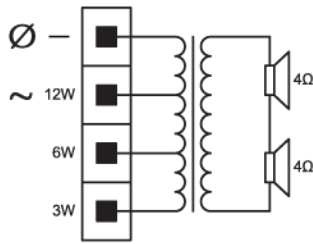

Circuit diagram

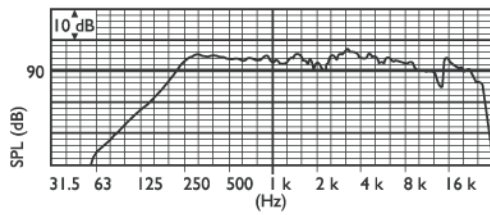

Frequency response

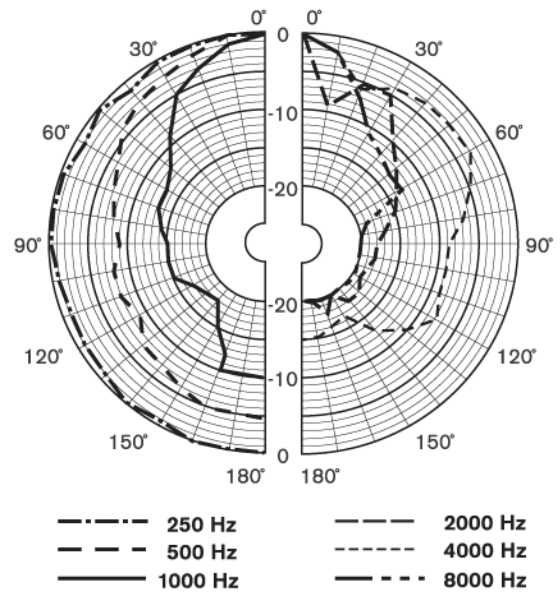

Polar diagram vertical (measured with pink noise)

Technical Specifications

Electrical*

Maximum power	18 W
Rated power	12 / 6 / 3 W
Sound pressure level at 12 W / 1 W (1 kHz, 1 m)	104 / 93 dB (SPL)
Effective frequency range (-10 dB)	160 Hz to 20 kHz

Opening angle	1 kHz / 4 kHz (-6 dB)
horizontal	195° / 95°
vertical	69° / 17°
Rated input voltage	100 V
Rated impedance	833 ohm
Connector	4-pole push-in terminal block

* Technical performance data acc. to IEC 60268-5

Mechanical

Dimensions (H x W x D)	441 x 151 x 150/111 mm (17.4 x 5.9 x 5.9/4.4 in)
Weight	2.5 kg (5.5 lb)
Color	Black (D) or white (L)
cabinet / cloth (D)	Matches RAL 9004 / RAL 9004
cabinet / cloth (L)	Matches RAL 9010 / RAL 7044

Environmental

Operating temperature	-25 °C to +55 °C (-13 °F to +131 °F)
Storage temperature	-40 °C to +70 °C (-40 °F to +158 °F)
Relative humidity	<95%

Ordering Information

LB1-UW12-D Cabinet Loudspeaker

12 W, black

LB1-UW12-L Cabinet Loudspeaker

12 W, white

Europe, Middle East, Africa:
Bosch Security Systems B.V.
P.O. Box 80002
5600 JB Eindhoven, The Netherlands
Phone: + 31 40 2577 284
Fax: +31 40 2577 330
emea.securitysystems@bosch.com
www.boschsecurity.com

Americas:
Bosch Security Systems, Inc.
130 Perinton Parkway
Fairport, New York, 14450, USA
Phone: +1 800 289 0096
Fax: +1 585 223 9180
security.sales@us.bosch.com
www.boschsecurity.us

Asia-Pacific:
Bosch Security Systems Pte Ltd
38C Jalan Pemimpin
Singapore 577180
Phone: +65 6319 3450
Fax: +65 6319 3499
apr.securitysystems@bosch.com
www.boschsecurity.com

Represented by